

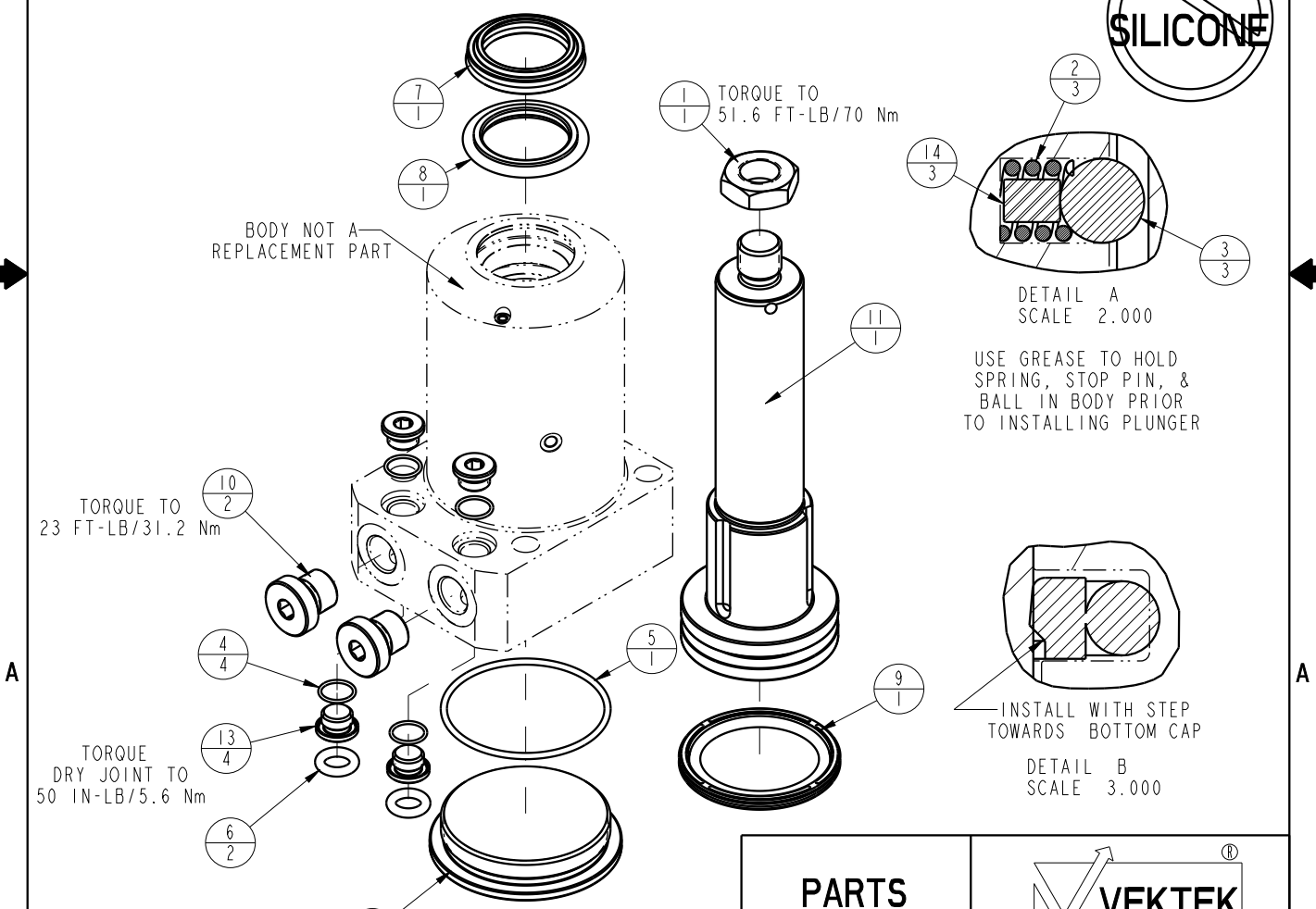

NO	QTY	PART NO	DESCRIPTION	SEAL KIT
1	1	21510003	NUT, JAM, HEX, M14-1.50	
2	3	23350086	SPRING, COMPRESSION	X
3	3	23650010	BALL, TUNGSTEN-CARBIDE, 6mm	X
4	4	39051080	O-RING, (10mm X 1)	X
5	1	39051084	O-RING, (50mm X 2)	X
6	2	39051088	O-RING, (8mm X 3)	X
7	1	39053045	SEAL, WIPER, SNAP IN, WED, 28, 94A, AU	X
8	1	39056005	SEAL, STEP, ROD, 28	X
9	1	39056024	SEAL, CAP, PISTON, 50, 90A, AU GRPHT FLD	X
10	2	43068006	PLUG, PORT, HOLLOW HEX, G1/4	
11	1	81400124	PLUNGER, SC, 7MPa, 50B, STR	
12	1	81400154	CAP, LC/SC, 7MPa, 50B	
13	4	81400201	PLUG, MANIFOLD, 7MPa, M10	
14	3	81400203	PIN, STOP, BALL, METRIC, 6mm BALL	X
N/A	N/A	L6014500	KIT, SEAL, SC, 7MPa, 50B	NOTED

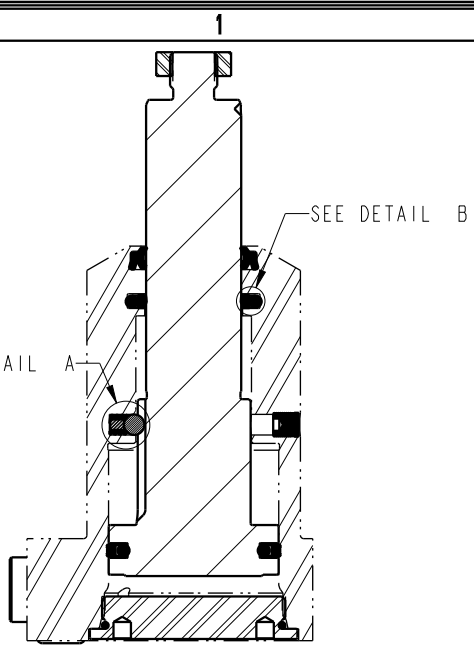

PARTS LIST	 VEKTEK VEKTEK, INC. 1334 E. SIXTH AVE. P.O. BOX 625 EMPORIA, KS. 66801 U.S.A.	
	ASSEMBLIES AFFECTED L1415000S	PARTS LIST, ASSY, SC, BF, 7MPa, 50B, STR
SIZE A	LPL1457	REV B

B	3273	RELEASE	JDW	08/15/18
REV	IN ACCORDANCE WITH ECN	EFFECTIVE DATE	REVISED BY	DATE
DRW BY:	TWA	DRAWING STATUS: ***		
DATE:	9-15-16	PRODUCTION APPROVED FOR RELEASED STATUS ONLY		